

## Built-in ZPA Logic Hybrid Driver Card No. HB-508S

HB-508S is the new generation of Built-in ZPA Logic Hybrid Driver Card. The HB-508S has both slug (train) tote release mode and singulated tote release mode along with sensor and jam timer functions to perfectly suit the most common ZPA conditions. In addition, The HB-508S provides the additional functions of flexible zone recognizing, synchronized speed variation, stable speed, and signal sentry function to satisfy even the most diverse and more sophisticated automation needs.



### 1 Features

- Achieves **both singulated and slug (train) tote release ZPA**
  - **Singulated release:** As soon as the sensor in the downstream zone detects that the zone is empty, the sensor signal will activate the occupied upstream zones to transfer the loaded tote on each zone, one by one.
  - **Slug (train) release mode:** As soon as the sensor in the downstream zone detects that the zone is empty, the sensor signal will activate all the occupied upstream zones simultaneously to transfer all the totes together.
- **Flexible zone recognition** (patented): The slug release mode also enables 'Flexible Zone Recognition'; Whatever the tote length is, and whenever the tote occupies multiple zones, the zones that are occupied by the tote are recognized as one zone to continuously achieve ZPA.
- **Sensor timer and jam timer function**
- **Signal sentry function**
- **Tote separation:** Plural totes can properly be separated zone by zone by having a singulated release function in the downstream of the slug (train) release zones.
- **Synchronized speed variation:** Synchronized speed variation of multiple zones is achieved simply by varying the analog voltage input to any one of the connected HB508S units.
- **1 zone plural motor drive:** The HB-508S has a RUN signal output to enable the synchronized driving of plural motors in one zone. This is useful when one zone is longer than others, or when the zone needs more than one motor to transfer heavier loads.
- Helps motor to have **Stable speed against varying load. (when the motor is running at nominal speed or less and applied load is less than the rated tangential force.**
- Applicable for both **PNP and NPN input signal** (by the Dip switch selection)
- **Simplified wiring** – totally 'plug & play'

## 2 Dimensions

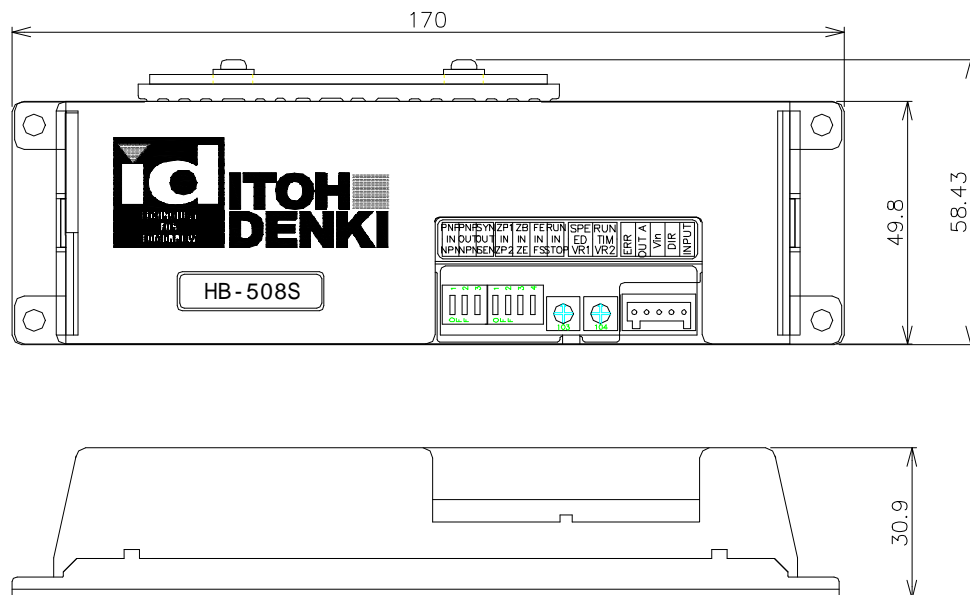

- CN1: Power connector (WAGO #734-132)
- CN2: I/O control connector (WAGO #733-335)
- CN3: Sensor connector (WAGO #733-363)
- CN4: Communication cable connector (MOLEX #52018-8845)
- CN5: Communication cable connector (MOLEX #52018-8845)
- CN6: Motor connector (not used)
- CN7: Motor connector (JST #S9B-XH-A)

## 3 Basic Specifications

Input Voltage : 24VDC +/- 10%  
 LEDs : LED 1 lights green when powered. LED 2 lights red in case thermal overload device reacts.

Applicable environment  
 Temperature: Between 0 and 40 (non freezing)  
 Humidity: 90% RH (no condensation)  
 Atmosphere: No corrosive gas  
 Vibration: 0.5G or less  
 Installation: Indoor

## 4 Applicable Motorized Roller

PM486FS/FE, PM500FS/FE, PM570ES, PM605ES series brushless DC motorized roller

## 5 Functions

### 5-1 ZPA function

- The HB-508S receives the signal of the sensor from the present zone when a tote enters the zone.
- The communication cables allow for signal exchanges with the next adjacent zones controlled by the HB-508S:
- Based on the signal, the HB-508S either receives the tote into or evacuates the tote from the present zone, depending on the occupied status in the present, and next adjacent up and downstream zones.
- ZPA modes (single or slug release) can be selected by the dip switch #2-1 setting. (See Section 7)
- In case HB-508S is used in the last downstream zone, the motor in the zone can be stopped by detecting tote presence (sensor ON) in the present zone. (This mode can be selected by dip switch #2-2 – See Section 7)

### 5-2 Sensor timer

- When the motor in the present zone is running, and if there's no further tote entry into the present zone for 5 seconds after the sensor turns OFF, and in addition, there is no tote presence in the next adjacent upstream zone, the motor in the present zone will be stopped by this sensor timer function.
- Timer setting:  $6 \pm 0.5$  seconds (fixed)

### 5-3 RUN holding timer (VR2)

- When the motor in the present zone is running and if there's no further tote entry in the present zone in the certain period of adjusted time after the sensor OFF in the same zone, the motor will be stopped.
- Time adjustable by integral potentiometer VR 2.
- Adjustable range of time: between 0.6 and 7.5 seconds

### 5-4 Jam timer

- When the present zone is in a sensor ON status (tote presence), thereby activating its motor, and if there's no sensor status change in the zone during 4 seconds after the tote is initially detected in the zone, this condition would indicate a jam, and the motor in the zone will be stopped. At the same time an error signal will be discharged.
- To correct the error (i.e. jam), the blocking tote should be removed to switch off the sensor.
- Jam timer setting: 4.5 seconds (fixed)

### 5-5 PNP / NPN input signal

Sensor, Sensor alarm, RUN, DIR (direction) input terminals accept both NPN and PNP signals by receiving the signal through a photo coupler. NPN or PNP signal input is selected by dip switch #1-1. (ON – PNP, OFF – NPN. See Section 7)

### 5-6 PNP / NPN output signal

Sensor, synchronization and error output signal can be either PNP or NPN open collector (selectable by dip switch #1-2. See Section 7)

Sensor signal output and synchronization signal output are alternative and can be selected by the dip switch #1-3 (See Section 7) In case both signal outputs are needed at the same time, the sensor signal output can be retrieved from the sensor terminal of CN3.



#### 5-7 Sensor input (CN3)

Sensor and sensor alarm outputs should be set to be ON when detecting tote.

#### 5-8 Motor Run (CN2)

- Motor will automatically be activated and stopped by ZPA logic function depending on the sensor status in the present, next adjacent up and downstream zones.
- Regardless of the ZPA logic, the motor will be forcibly activated by switching on (close) the input terminal. (in case the dip switch 2-4 is ON setting) (the motor is subject to ZPA logic when the contact is open) RUN input signal should be 1 shot pulse.

#### 5-9 Motor reversing (CN2)

- Switching on the DIR (direction) input terminal will make the same HB 508S connected to CN5 be upstream, and the one to CN4 be downstream.
- Reversing the motor by DIR input terminal will automatically reverse the motor in next adjacent up and downstream zone.
- Transfer direction of the multiple zones (maximum up to 30 zones) can be reversed simultaneously by reversing command signal from one of these zones, as all these zones are linked with communicated cable containing direction command signal.
- Single motor direction can be reversed by the dip switch #2-3 setting (because motor turning direction of FS and FE unit differs respectively)
- When the DIR terminal is ON, the motor must run toward CW direction. Thus, the dip switch #2-3 must be ON for FS series motor, and be OFF for FE series motor.

#### 5-10 Sensor signal output (CN2)

- Output of the sensor signal of the present zone. (discharged from CN2 terminal 4, when the dip switch #1-3 is OFF. Output transistor will be ON, when detecting tote (sensor ON))

#### 5-11 Error signal output (CN2, LED 2)

- Error signal output terminal in CN2 terminal 5 will discharge a signal if all the HB 508S in the zones linked through the communication cable are in normal status.
- Output transistor is ON in normal status. (to allow error output in case of fuse failure)
- Failed (troubled) zone can easily be identified by the LED 1 (lights green when powered – normal status) and LED 2 (lights red in case of error) in the individual HB 508.
- Error signal is discharged at any of the following failures:
  - reaction of thermal overload device either circuitry (> 85 °C) or motor (> 105 °C) (motor continue to run with lowered output, lighting LED 2 red, and keeps achieving ZPA)
  - Jam timer setting time over (stops motor to cease ZPA, lighting LED 2)
  - Reaction of the sensor alarm (motor continue to run with lowered output, lighting LED 2 red, and keeps achieving ZPA)

#### 5-12 Synchronization signal output (CN2)

- Synchronization signal is discharged when the motor in the present zone starts running.
- This signal enables synchronized motor operation in plural zones connected by the communication cable to individual HB 508S.
- This also allows the synchronized operation of the plural motors in the same zone.
- CN2 terminal #4 will be synchronization signal output terminal if the dip switch #1-3 is set ON.
- Transistor of open collector out becomes ON, when running (max 25mA)



#### 5-13 Speed variation (VR1)

- Motor speed can be varied by turning the integral potentiometer VR1.
- Speed of the plural motors can be simultaneously varied by varying the analog voltage input (0 – 10V) to the CN2 #3 terminal, if each of these zones is operated by HB 508 and are connected through the communication cable. In this case, the integral potentiometer VR1 should be turned to minimum.
- 20mA current is consumed at 10V. This means 400mA capacity is needed to control 20 zones.
- Variable speed range is between 20 and 100% of the motor speed.

#### 5-14 Communication terminal (CN4, CN5)

- Allows the communication of sensor signal, and the motor drive status signal among the present zone, up and downstream zones.
- Transmits the transfer direction signal.
- Transmits external speed variation signal.
- Transmits the error signal.

#### 5-15 Power indication (LED 1)

- Lights green when powered (24V and 0V are supplied to CN1)

#### 5-16 Connection to the HB 508S in the other zones

- If the HB-508S in the upstream zone is not connected by communication cable to the one in the present zone, tote entry into the present zone will be done only with RUN input terminal.
- Tote evacuation from the present zone is done according to its ZPA logic. In case tote entry is done by RUN input terminal, the tote existence of the zone must be recognized by sensor signal output, so as to prevent the bumping of totes. The program has been made accordingly to prevent the bumping of the totes.
- If the HB-508S in the downstream zone is not connected to the one in the present zone with the communication cable, tote entry is done by ZPA logic.
- Evacuation from the zone will be done only by the external RUN signal output, if the Dip Switch #2-2 is set to OFF. If the Dip Switch #2-2 is set to ON, tote will be automatically evacuated from the zone as in normal ZPA, recognizing the next adjacent downstream zone is empty.

#### 5-17 Protections

- Thermal Overload Device: Reacts either at 105 °C inside motor, or 85 °C on PCB, to lower the motor output to prevent motor overheat and burnout. When this reacts, LED will also light red.
- Current Limiter: is set at 3A maximum (motor locking current is 3A)
- 5A fuse

#### 5-18 ZPA Signal Sentry function

By setting the dip switch 2-4 OFF, the corresponding zone is forcibly stopped by inputting forcible stop signal (the zone receives the incoming tote from the next upstream zone, but won't evacuate it to the next downstream zone).

## 6 Connector Specifications

### 6-1 CN1 Power Connector (2P)

	Wago #734-132 For driver side	WAGO #734-102 For control cable side
1	+24VDC	Wire AWG28 ~ 14
2	0V	Input 100W or over

### 6-2 CN2 Control Connector (5P)

	WAGO #733-335 For driver side	WAGO #733-105 (option) For control cable side
1	Terminal input	Wire AWG28 ~ 20
2	DIR input	Input +24V/0V
3	Speed variation voltage input	Output: Open collector
4	Synchronization/sensor output	(Max 25mA DC)
5	Error output	

### 6-3 CN3 Sensor Connector (3P)

	WAGO #733-363 For driver side	WAGO #733-103 For control cable side
1	+24VDC	Wire AWG28 ~ 20
2	Sensor	Sensor should be set to be ON to discharge a signal when detecting
3	0V	

### 6-4 CN4 Communication Connector (8P)

	MOLEX #52018-8845 For driver side	Hirose #TM10P-88P equivalent (Option) For control cable side
1	Sensor signal output	Wire AWG26 equivalent
2	Sensor signal input	
3	Speed variation	
4	Error signal	
5	Drive input	
6	Drive output	
7	Direction signal	
8	GND	

### 6-5 CN5 Communication Connector (8P)

	MOLEX #52018-8845 For driver side	Hirose #TM10P-88P equivalent (Option) For control cable side
1	Sensor signal input	Wire AWG26 equivalent
2	Sensor signal output	8P
3	Speed variation	
4	Error signal	
5	Drive output	
6	Drive input	
7	Direction signal	
8	GND	

## 6-6 CN7 Motor Connector (9P)

	JST #S9B-XH-A 9P For driver side	JST #XHP-9 Mounted to the motor cable
1	GND (gray)	Pressured connection terminal #DF3-22SCF (supplied in reel) Wire AWG28 ~ 22 except AWG24 ~ 22 used for motor phases  * brake option is customized
2	+12V (blue)	
3	Motor phase U (red)	
4	Motor phase V (white)	
5	Motor phase W (black)	
6	Hall sensor U (violet)	
7	Hall sensor V (orange)	
8	Hall sensor W (green)	
9	Thermister (light blue)	

## 7 Dip Switches

	SW #	Function	Setting	Standard Setting
Dip Sw 1	1	PNP/NPN input signal switching	ON – PNP, OFF – NPN	ON
	2	PNP/NPN output signal switching	ON – PNP, OFF – NPN	ON
	3	Switching of synchronization and sensor output	ON – Synchronization output OFF – Sensor signal output	ON
Dip Sw 2	1	Switching of singulated and slug release mode	ON – slug (train) release mode OFF – singulated release mode	ON
	2	Last downstream zone setting	ON – Normal zone OFF – The last downstream zone	ON
	3	Motor setting FS or FE	ON – FE unit OFF – FS unit	ON
	4	Forcible RUN/Forcible Stop	ON – Forcible RUN OFF – Forcible Stop	ON

## 8 Wiring Diagramme

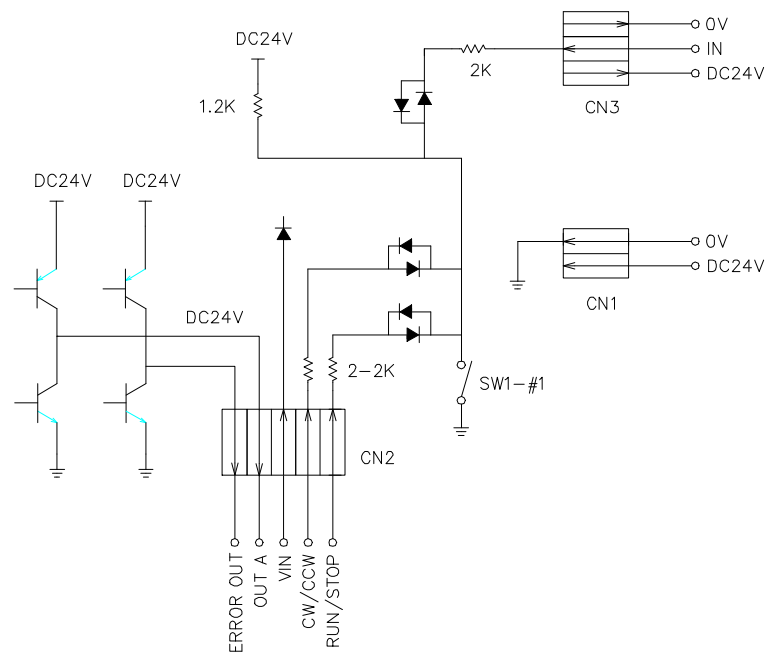

## 9 Accessories

- Communication Cable supplied with connector on both ends (length to be specified)
- CN1 Connector Plug (WAGO 734-102)
- CN2 Connector Plug (WAGO 733-105) – **Option**
- CN3 Connector Plug (WAGO 733-103)
- Screw M4 (Ep-Fe/Zn 5/CM 2C) X 4
- Spring Washer M4 (Ep-Fe/Zn 5/CM 2C) X 4
- Hex. Nut M4 (Ep-Fe/Zn 5/CM 2C) X 4

## 10 How to order

Simply tell us the following designation

Hybrid Board: HB 508S

Communication Cable: CAHB08 – XXXX (specify the cable length in mm in 4 digits. In case of 500mm for instance, CAHB08 – 0300.

Specifications are subject to change without prior notice.